

2007-08 Elite Referees' Fitness Programme: The road to excellence



p. 1 / 18

WEEK 7 from Monday 11th to Sunday 17th of February **Macrocycle VII, week 1 (Training week 37)**

- Mon. 11th: * Act. Rec. - 50' recovery session in a fitness centre
Tr. 137
- Tue. 12th: * Low Int. - 5' jogging slowly building up to 70% HR_{max} (± 1 km)
Tr. 138
- * Warm up - 20' extensive warm up, mobilisation and stretching
- * Strength - 6 x 30 sit-ups, separated by 6 x 10 push-ups, in addition to the regular set of strength and injury prevention exercises
- * High Int. - Set 1
- 20" run at 90% HR_{max} (± 100 m), 10" jogging
- 40" run at 90% HR_{max} (± 200 m), 20" jogging
- 60" run at 90% HR_{max} (± 300 m), 30" jogging
- 80" run at 90% HR_{max} (± 400 m), 40" jogging
- 20" run at 90% HR_{max} (± 100 m), 10" jogging
- 40" run at 90% HR_{max} (± 200 m), 20" jogging
- 60" run at 90% HR_{max} (± 300 m), 30" jogging
- 80" run at 90% HR_{max} (± 400 m), 40" jogging
- 2' recovery
- Set 2
- 80" run at 90% HR_{max} (± 400 m), 40" jogging
- 60" run at 90% HR_{max} (± 300 m), 30" jogging
- 40" run at 90% HR_{max} (± 200 m), 20" jogging
- 20" run at 90% HR_{max} (± 100 m), 10" jogging
- 80" run at 90% HR_{max} (± 400 m), 40" jogging
- 60" run at 90% HR_{max} (± 300 m), 30" jogging
- 40" run at 90% HR_{max} (± 200 m), 20" jogging
- 20" run at 90% HR_{max} (± 100 m), 10" jogging
- All together, this takes 10' + 2' recovery + 10' = 22'
- * Cool down - 5' jogging and walking, followed by 10' extensive stretching

Total duration: 72'

Wed. 13th: REST DAY

- Thu. 14th: * Low Int. - 5' jogging slowly building up to 70% HR_{max} (± 1 km)
Tr. 139
- * Warm up - 20' extensive warm up, mobilisation and stretching

2007-08 Elite Referees' Fitness Programme: The road to excellence



p. 2 / 18

- * Strength - 6 x 30 sit-ups, separated by 6 x 10 push-ups, in addition to the regular set of strength and injury prevention exercises
- * High Int.
 - Set 1
 - Referees perform 5 laps as follows:
 - From the start, run at the appropriate intensity around the pitch perimeter.
 - However, on LAP 1 run around cone 1, and so on up to cone 5 on LAP 5, thus increasing the run distance with each subsequent lap.
 - The running should be $\frac{3}{4}$ pace (the HR that it will elicit should be 85-95%HR_{max}).

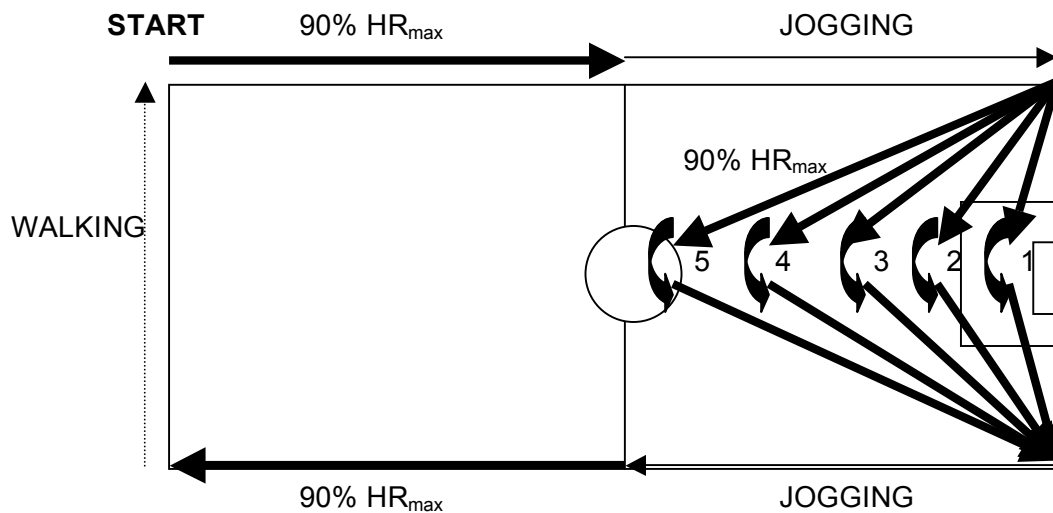

- 4' recovery

- Set 2

- However, on LAP 1 run around cone 5, and so on up down to cone 1 on LAP 5, thus decreasing the run distance with each subsequent lap

- All together this exercise takes $\pm 24'$

(10' Set 1 + 4' recovery + 10' Set 2)

- * Match - 10' match play
- * Cool down - 5' jogging and walking, followed by 10' extensive stretching

Total duration: 84'

Fri. 15th:

REST DAY

2007-08 Elite Referees' Fitness Programme: The road to excellence



p. 3 / 18

- Sat. 16th: * Warm up - 20' extensive warming up, mobilisation and stretching
Tr. 140
- * Speed - 5 maximal sprints in the order illustrated below
- Walk back to the start after each individual sprint.
- Once the 5 sprints (140 m total sprinting distance) have been completed take a 5' stretching break

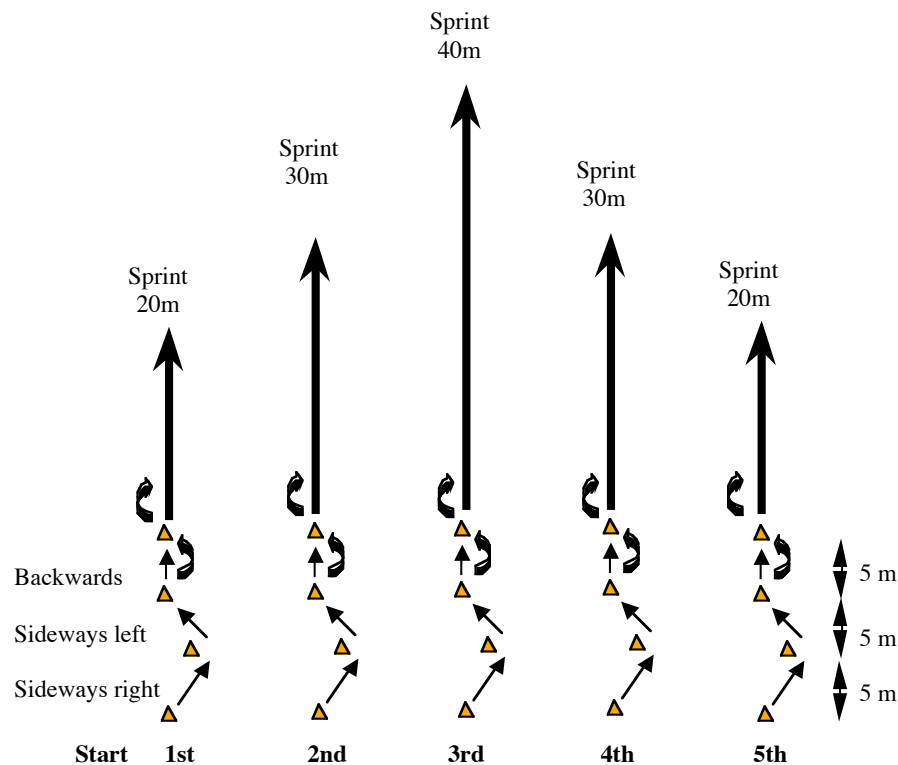

- Then perform a second set of sprints for a session total of 10 sprints. Start the sprints this time sideways right, and turn on the opposite shoulder to the first set when turning from backwards jogging to sprinting

- The total exercise time is 15'

- * Cool down - 5' jogging and walking, followed by 10' extensive stretching

Total duration: 50'

Sun. 17th: Those referees who don't have a game to officiate in the weekend, may do some intermittent activities such as playing badminton, football, squash, or tennis.

2007-08 Elite Referees' Fitness Programme:

The road to excellence



p. 4 / 18

WEEK 8 from Monday 18th to Sunday 24th of February

Macrocycle VII, week 2 (Training week 38)

- Mon. 18th: * Act. Rec. - 50' recovery session in a fitness centre
Tr. 141
- Tue. 19th: * Low Int. - 5' jogging slowly building up to 70% HR_{max} (± 1 km)
Tr. 142
- * Warm up - 20' extensive warm up, mobilisation and stretching
- * Strength - 6 x 30 sit-ups, separated by 6 x 10 push-ups, in addition to the regular set of strength and injury prevention exercises
- * High Int. - Set 1
- 30" run at 90% HR_{max} (± 150 m), then 30" recovery jogging
- 60" run at 90% HR_{max} (± 300 m), followed by 30" jogging
- 90" run at 90% HR_{max} (± 450 m), followed by 30" jogging
- 2' run at 90% HR_{max} (± 600 m), followed by 1' jogging
- 90" run at 90% HR_{max} (± 450 m), followed by 30" jogging
- 60" run at 90% HR_{max} (± 300 m), followed by 30" jogging
- 30" run at 90% HR_{max} (± 150 m), followed by 30" jogging
- 4' recovery
- Set 2
- Perform the same sequence as prescribed in Set 1
- All together, this exercise takes 12' + 4' recovery + 12' = 28'
- * Cool down - 5' jogging and walking, followed by 10' extensive stretching
- Total duration: 78'

Wed. 20th: REST DAY

- Thu. 21st: * Low Int. - 5' jogging slowly building up to 70% HR_{max} (± 1 km)
Tr. 143
- * Warm up - 20' extensive warm up, mobilisation and stretching
- * Strength - 6 x 30 sit-ups, separated by 6 x 10 push-ups, in addition to the regular set of strength and injury prevention exercises
- * Speed End. - Set 1
- 2 laps of the following field exercise

2007-08 Elite Referees' Fitness Programme: The road to excellence



p. 5 / 18

- One lap consists of 7 sub-maximal sprints followed by 7 recovery jogs. The maximum tempo should consist of 90% of maximal speed. The jogging should take 3 x longer than the duration of the tempo run. After reaching the finish, referees jog all along the goal line until the next corner and then walk back to the start position. It takes $\pm 13'$ to do 2 full laps.

- 4' recovery

- Set 2

- Again 2 laps of 7 sub-maximal sprints each

- In total, the exercise takes $\pm 30'$

(13' Set 1 + 4' recovery + 13' Set 2).

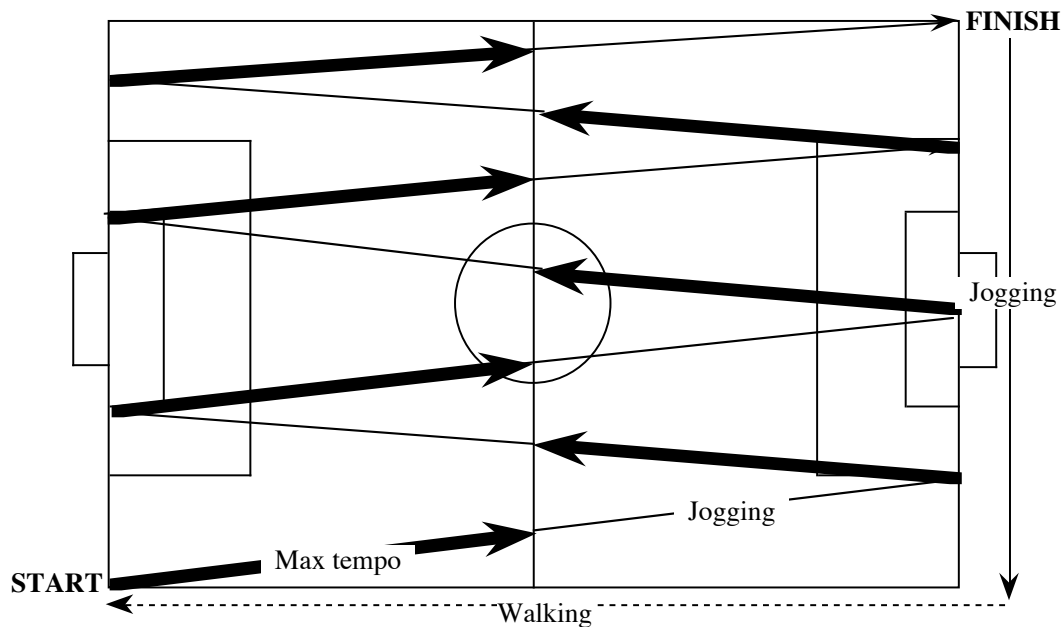

* Match - 10' match play

* Cool down - 5' jogging and walking, followed by 10' extensive stretching

Total duration: 90'

Fri. 22nd.

REST DAY

2007-08 Elite Referees' Fitness Programme: The road to excellence



p. 6 / 18

- Sat. 23rd: * Warm up - 20' extensive warming up, mobilisation and stretching
Tr. 144
- * Speed
- 10 m sprint up, 10 m walk down, 4 x
 - 20 m sprint up, 20 m walk down, 3 x
 - 30 m sprint up, 30 m walk down, 2 x
 - 40 m sprint up, 40 m walk down, 1 x

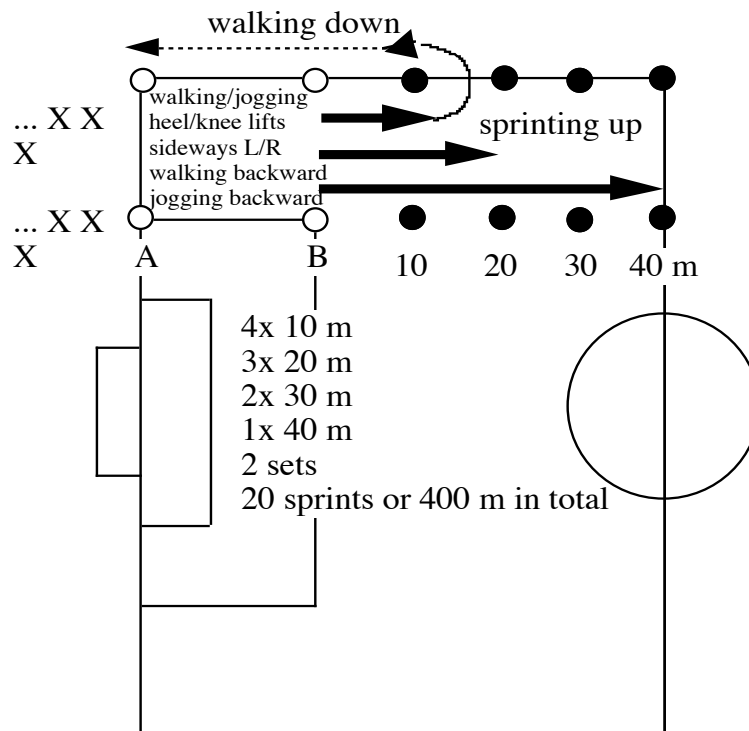

- Once the 10 sprints (200 m total sprinting distance) have been completed take a 5' recovery, stretching and drinking break.

- Then perform a second set of sprints but now in reversed order, i.e. from 40 m to 10 m, for another total of 10 sprints.

- The total exercise time is 15', with the total sprint distance being 400 m.

- * Cool down - 5' jogging and walking, followed by 10' extensive stretching

Total duration: 50'

Sun. 24th: Those referees who don't have a game to officiate in the weekend, may do some intermittent activities such as playing badminton, football, squash, or tennis.

2007-08 Elite Referees' Fitness Programme: The road to excellence



p. 7 / 18

WEEK 9 from Monday 25th of February to Sunday 2nd of March Macrocycle VII, week 3 (Training week 39)

- Mon. 25th: * Act. Rec. - 50' recovery session in a fitness centre
Tr. 145
- Tue. 26th: * Low Int. - 5' jogging slowly building up to 70% HR_{max} (± 1 km)
Tr. 146
- * Warm up - 20' extensive warm up, mobilisation and stretching
- * Strength - 6 x 30 sit-ups, separated by 6 x 10 push-ups, in addition to the regular set of strength and injury prevention exercises
- * Speed End. - Set 1
- Field exercise, 8 laps in total from the start as follows:
- Sideways-R (± 15 m)
- Jog to next cone (± 40 m)
- Backwards jogging to the next cone (± 15 m)
- HI running around the top cone and to the next cone (± 100m)
- Running backwards to the next cone (± 15 m)
- Jogging at medium intensity to the next cone (± 40 m)
- Sideways-L (± 15 m)
- Walk back to start (± 60 m)
- One full lap, arriving back at the start takes ± 90".
- Therefore restart every 90".
- Set 1 (8 laps) takes ± 12' to complete
- 4' recovery
- Set 2: Field exercise, again 8 laps of 90" each
- All together, this speed endurance exercise takes ± 28'
(12' Set 1 + 4' recovery + 12' Set 2)

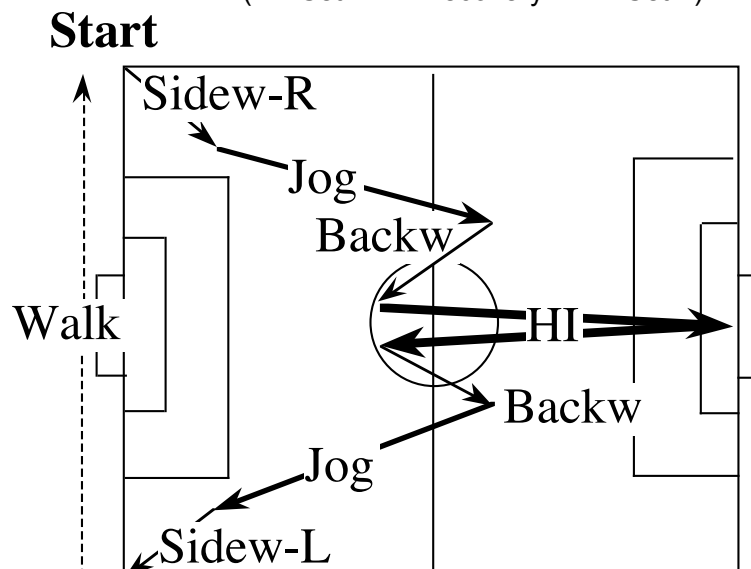

2007-08 Elite Referees' Fitness Programme:

The road to excellence



p. 8 / 18

* Cool down - 5' jogging and walking, followed by 10' extensive stretching

Total duration: 78'

Wed. 27th: REST DAY

Thu. 28th: * Low Int. - 5' jogging slowly building up to 70% HR_{max} (± 1 km)
Tr. 147

* Warm up - 20' extensive warm up, mobilisation and stretching

* Strength - 6 x 30 sit-ups, separated by 6 x 10 push-ups, in addition to the regular set of strength and injury prevention exercises

* Ext Sp - Set 1:
> 8 sprints of 20 m (± 3") with 20" active recovery in between each sprint
> Jog 1 lap of the pitch (± 2'30")
> Duration Set 1: ± 6'

- Set 2:
> 6 sprints of 40 m (± 6") with 40" active recovery in between each sprint
> Jog 1 lap of the pitch (± 2'30")
> Duration Set 2: ± 7'

- Set 3:
> 4 sprints of 60 m (± 9") with 60" active recovery in between each sprint
> Jog 1 lap of the pitch (± 2'30")
> Duration Set 3: ± 9'

- Set 4:
> 2 sprints of 80 m to the opposite penalty box (± 12") with 80" active recovery in between each sprint
> Duration Set 4: ± 3'

- The total duration of this extended speed session is ± 25'

* Match - 10' match play

* Cool down - 5' jogging and walking, followed by 10' extensive stretching

Total duration: 85'

Fri. 29th: REST DAY

2007-08 Elite Referees' Fitness Programme: The road to excellence



p. 9 / 18

- Sat. 1st.
Tr. 148
- * Warm up - 20' extensive warming up, mobilisation and stretching
 - * Speed
 - Short sprints from a dynamic start:
 - 2 x 5 m, 2 x 10 m, 2 x 15 m, 2 x 20 m and 2 x 25 m (with a change in direction to the left)
 - 5' recovery
 - The second set of the 10 sprints is done in reversed order, i.e. 2 x 25 m (with a change in direction to the right), 2 x 20 m, 2 x 15 m, 2 x 10 m and 2 x 5 m

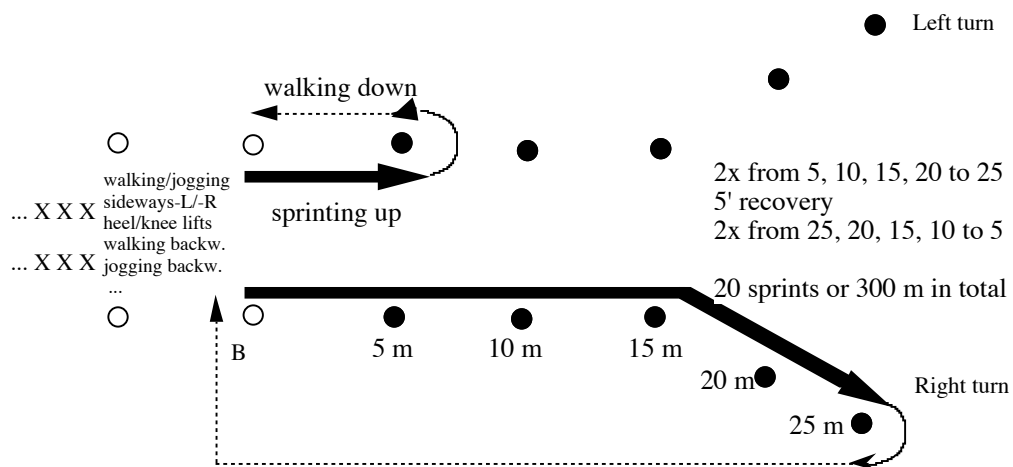

- The total exercise time is 15'
- * Cool down - 5' jogging and walking, followed by 10' extensive stretching

Total duration: 50'

Sun. 2nd. Those referees who don't have a game to officiate in the weekend, may do some intermittent activities such as playing badminton, football, squash, or tennis.

2007-08 Elite Referees' Fitness Programme:

The road to excellence



p. 10 / 18

WEEK 10 from Monday 3rd to Sunday 9th of March

Macrocycle VII, week 4 (Training week 40)

- Mon. 3rd: * Act. Rec. - 50' recovery session in a fitness centre
Tr. 149
- Tue. 4th: * Low Int. - 5' jogging slowly building up to 70% HR_{max} (± 1 km)
Tr. 150
- * Warm up - 20' extensive warm up, mobilisation and stretching
- * Strength - 6 x 30 sit-ups, separated by 6 x 10 push-ups, in addition to the regular set of strength and injury prevention exercises
- * High Int. Set 1
- 30" run at 90% HR_{max}, followed by 30" recovery jogging
 - 45" run at 90% HR_{max}, followed by 30" jogging
 - 60" run at 90% HR_{max}, followed by 30" jogging
 - 75" run at 90% HR_{max}, followed by 30" jogging
 - 30" run at 90% HR_{max}, followed by 30" jogging
 - 45" run at 90% HR_{max}, followed by 30" jogging
 - 60" run at 90% HR_{max}, followed by 30" jogging
 - 75" run at 90% HR_{max}, followed by 30" jogging
- 4' recovery
- Set 2
- 75" run at 90% HR_{max}, followed by 30" jogging
 - 60" run at 90% HR_{max}, followed by 30" jogging
 - 45" run at 90% HR_{max}, followed by 30" jogging
 - 30" run at 90% HR_{max}, followed by 30" jogging
 - 75" run at 90% HR_{max}, followed by 30" jogging
 - 60" run at 90% HR_{max}, followed by 30" jogging
 - 45" run at 90% HR_{max}, followed by 30" jogging
 - 30" run at 90% HR_{max}, followed by 30" jogging
- All together, this exercise takes 11' + 4' recovery + 11' = 26'
- From a coaching point of view, the easiest way to do this intermittent exercise, is to give a clear signal each time the referees have to change from activity.
- For Set 1, the time line for the use of the whistle is as follows:
0 (30" HI) - 30" (J) - 1' (HI) - 1'45" (J) - 2'15" (HI) - 3'15" (J) - 3'45" (HI) - 5' (J) - 5'30" (HI) - 6' (J) - 6'30" (T) - 7'15" (J) - 7'45" (HI) - 8'45" (J) - 9'15" (HI) - 10'30" (J) - 11' (Finish)
- For Set 2, the time line is:
0 (75" HI) - 1'15" (J) - 1'45" (HI) - 2'45" (J) - 3'15" (HI) - 4' (J) - 4'30" (HI) - 5' (J) - 5'30" (HI) - 6'45" (J) - 7'15" (HI) - 8'15" (J) - 8'45" (HI) - 9'30" (J) - 10' (HI) - 10'30" (J) - 11' (Finish)

2007-08 Elite Referees' Fitness Programme: The road to excellence



p. 11 / 18

* Cool down - 5' jogging and walking, followed by 10' extensive stretching

Total duration: 76'

Wed. 5th: REST DAY

Thu. 6th: * Low Int. - 5' jogging slowly building up to 70% HR_{max} (± 1 km)
Tr. 151

* Warm up - 20' extensive warm up, mobilisation and stretching

* Strength - 6 x 30 sit-ups, separated by 6 x 10 push-ups, in addition to the regular set of strength and injury prevention exercises

* Speed End. - Set 1
- 4 laps of ± 3' each

- 4' recovery

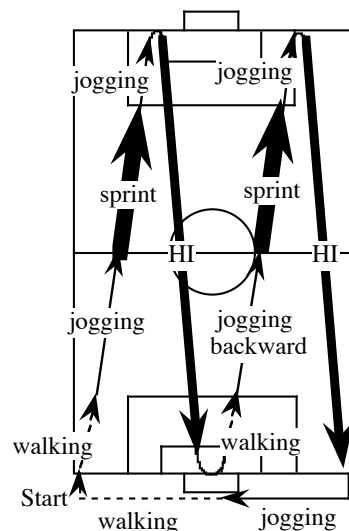

- Set 2
- 4 laps of ± 3' each

- All together this exercise takes ± 28'
(12' Set 1 + 4' recovery + 12' Set 2)

* Match - 10' match play

* Cool down - 5' jogging and walking, followed by 10' extensive stretching

Total duration: 88'

Fri. 7th: REST DAY

2007-08 Elite Referees' Fitness Programme: The road to excellence



p. 12 / 18

Sat. 8th: * Warm up - 20' extensive warming up, mobilisation and stretching
Tr. 152

* Speed/Agility - Penalty box exercise, as per diagram below

- Set 1

3 reps in the penalty box from start to finish as indicated

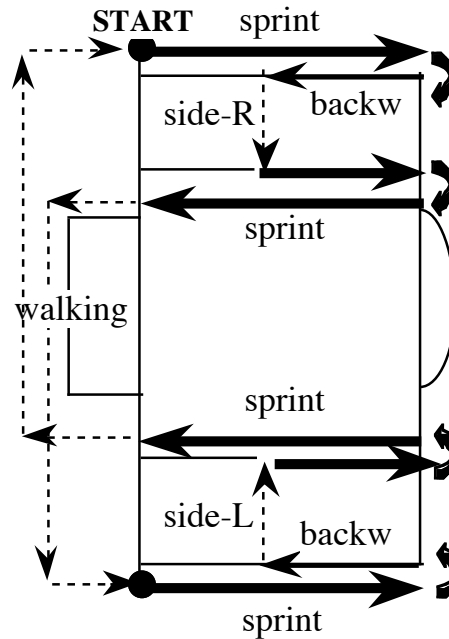

- Set 2

- Perform another 3 reps of the penalty box exercise

- If referees have a training session in group (i.e. with other referees), then this exercise can also be done as a relay race

- The total exercise time is 15'

* Cool down - 5' jogging and walking, followed by 10' extensive stretching

Total duration: 50'

Sun. 9th: Those referees who don't have a game to officiate in the weekend, may do some intermittent activities such as playing badminton, football, squash, or tennis.

2007-08 Elite Referees' Fitness Programme: The road to excellence



p. 13 / 18

WEEK 11 from Monday 10th to Sunday 16th of March Macrocycle VII, week 5 (Training week 41)

- Mon. 10th: * Act. Rec. - 50' recovery session in a fitness centre
Tr. 153
- Tue. 11th: * Low Int. - 5' jogging slowly building up to 70% HR_{max} (± 1 km)
Tr. 154
- * Warm up - 20' extensive warm up, mobilisation and stretching
- * Strength - 6 x 30 sit-ups, separated by 6 x 10 push-ups, in addition to the regular set of strength and injury prevention exercises
- * High Int. - This HI-run can easily be performed on a track (Start A) or on a regular field of play (Start A').
- Each run is performed at 90% of HR_{max}
- Set 1
- 300 m run in 50-60", 50-60" recovery, 7 reps
- 6' recovery
- Set 2
- Repeat the 300 m run in 50-60", 50-60", recovery, 7 reps
- If the exercise is performed on the field of play, then the start of Set 2 is on the opposite side so that referees have to turn on the other shoulder

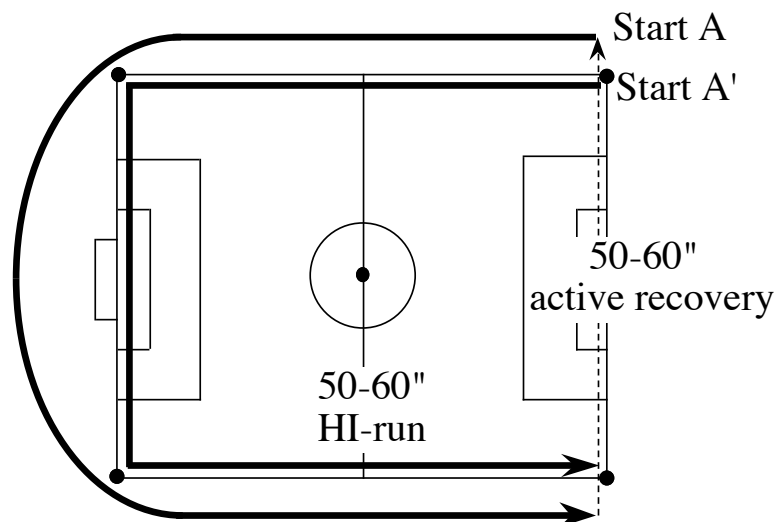

- All together, these 16 HI-runs take ± 34'
(14' Set 1 + 6' recovery + 14' Set 2)

- * Cool down - 5' jogging and walking, followed by 10' extensive stretching

Total duration: 84'

2007-08 Elite Referees' Fitness Programme: The road to excellence



p. 14 / 18

Wed. 12th:

REST DAY

Thu. 13th:
Tr. 155

- * Low Int. - 5' jogging slowly building up to 70% HR_{max} (± 1 km)
- * Warm up - 20' extensive warm up, mobilisation and stretching
- * Strength - 6 x 30 sit-ups, separated by 6 x 10 push-ups, in addition to the regular set of strength and injury prevention exercises
- * High Int.
 - Set 1
 - Perform the pitch laps below in the following order:
 - Lap 1, Lap 2, Lap 3, Lap 4, Lap 5, Lap 5, Lap 4, Lap 3, Lap 2 and finishing off with Lap 1
 - Each run is performed at 90% HR_{max}
 - With no recovery breaks in-between each lap it takes ± 13' to run Set 1.

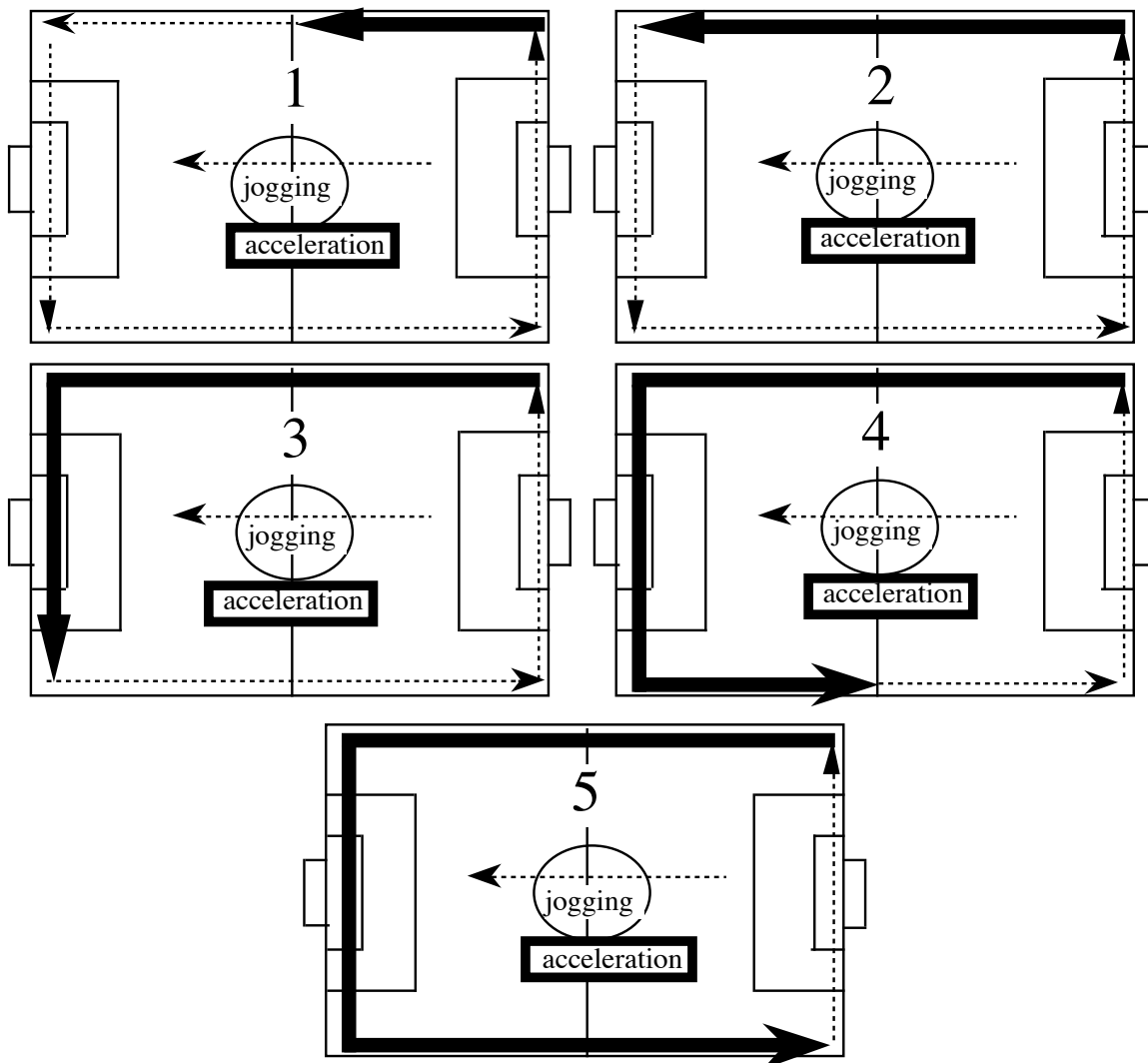

2007-08 Elite Referees' Fitness Programme: The road to excellence



p. 15 / 18

- 4' recovery
- * Speed End.
 - Set 2
 - Perform the pitch laps below in the following order:
 - Lap 5, Lap 4, Lap 3, Lap 2, Lap 1, Lap 1, Lap 2, Lap 3, Lap 4 and finishing off with Lap 5.
 - All together this exercise takes $\pm 30'$
(13' Set 1, 4' recovery, 13' set 2)
- * Match - 10' match play
- * Cool down - 5' jogging and walking, followed by 10' extensive stretching

Total duration: 90'

Fri. 14th: REST DAY

- Sat. 15th: * Warm up - 20' extensive warming up, mobilisation and stretching
Tr. 156
- * Speed - Variations on the centre circle sprint:
- Set 1: 5' or 5 laps in total
 - 3' recovery and stretching
 - Set 2: 5' or 5 laps in total

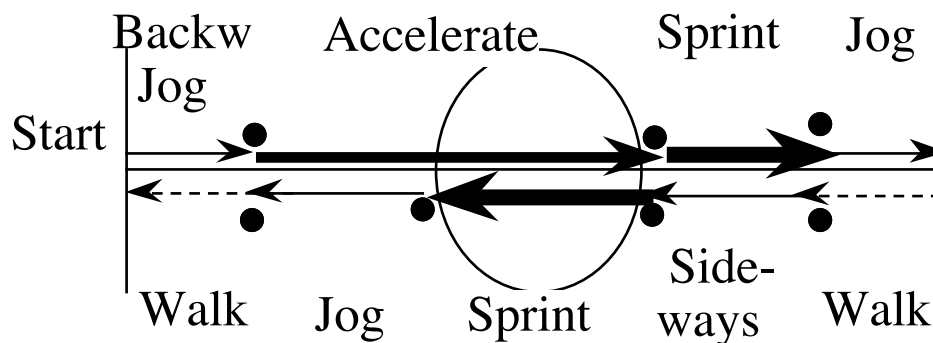

- The total exercise time is 15'

- * Cool down - 5' jogging and walking, followed by 10' extensive stretching

Total duration: 51'

Sun. 16th: Those referees, who don't have a game to officiate in the weekend, may do some intermittent activities such as playing badminton, football, squash, or tennis.

2007-08 Elite Referees' Fitness Programme:

The road to excellence



p. 16 / 18

WEEK 12 from Monday 17th to Sunday 23rd of March Macrocycle VII, week 6 (Training week 42)

- Mon. 17th: * Act. Rec. - 50' recovery session in a fitness centre
Tr. 157
- Tue. 18th: * Low Int. - 5' jogging slowly building up to 70% HR_{max} (± 1 km)
Tr. 158
- * Warm up - 20' extensive warm up, mobilisation and stretching
- * Strength - 6 x 30 sit-ups, separated by 6 x 10 push-ups, in addition to the regular set of strength and injury prevention exercises
- * Extended Sp. - This session is an extension of a previous extended speed session
- Set 1:
- > 2 maximal 75 m sprints (± 10")
with 75" recovery jogging in between each sprint
 - > 4 maximal 50 m sprints (± 7")
with 50" recovery jogging in between each sprint
 - > 6 maximal 25 m sprints over 25 m (± 4")
with 25" recovery jogging in between each sprint
 - > Jog 1 lap of the pitch (± 2'30")
 - > Duration Set 1: ± 12'
- Set 2:
- > 6 maximal 25 m sprints over 25 m (± 4")
with 25" recovery jogging in between each sprint
 - > 4 maximal 50 m sprints (± 7")
with 50" recovery jogging in between each sprint
 - > 2 maximal 75 m sprints (± 10")
with 75" recovery jogging in between each sprint
 - > Jog 1 lap of the pitch (± 2'30")
 - > Duration Set 2: ± 12'
- The total duration of this extended speed session is ± 24' including 5' active recovery.
- * Cool down - 5' jogging and walking, followed by 10' extensive stretching

Total duration: 74'

Wed. 19th: REST DAY

- Thu. 20th: * Low Int. - 5' jogging slowly building up to 70% HR_{max} (± 1 km)
Tr. 158
- * Warm up - 20' extensive warm up, mobilisation and stretching
- * Strength - 6 x 30 sit-ups, separated by 6 x 10 push-ups, in addition to the regular set of strength and injury prevention exercises

2007-08 Elite Referees' Fitness Programme: The road to excellence



p. 17 / 18

- * Speed End.
- Set 1
- Field exercise, 5 laps of $\pm 2'$ each performing the different activities at the appropriate intensities

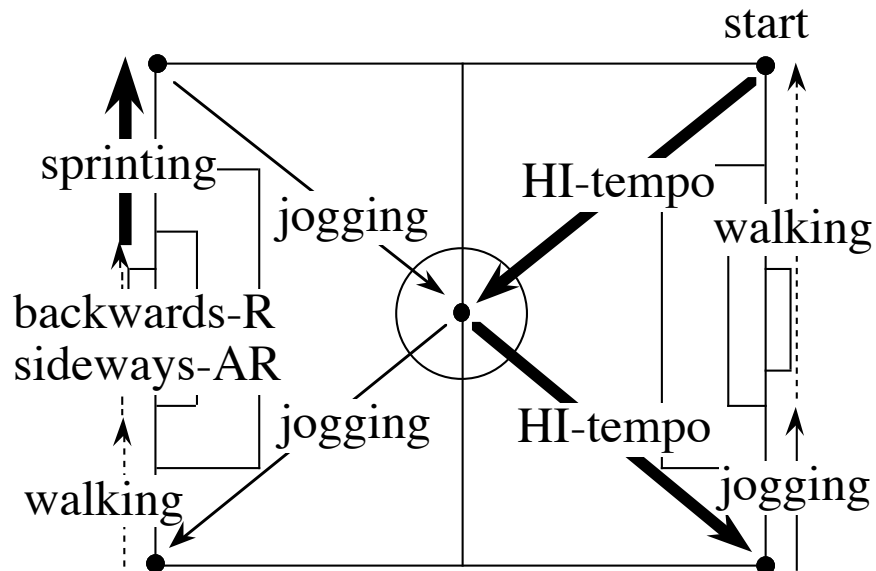

- 4' recovery

- Set 2
- Field exercise, 5 laps of $\pm 2'$ each
- All together this exercise takes 24'
(10' Set 1 + 4' recovery + 10' Set 2)

- * Match - 10' match play
- * Cool down - 5' jogging and walking, followed by 10' extensive stretching

Total duration: 84'

Fri. 21st.

REST DAY

2007-08 Elite Referees' Fitness Programme: The road to excellence



p. 18 / 18

- Sat. 22nd: * Warm up - 20' extensive warming up, mobilisation and stretching
Tr. 160
- * Speed
- 1) 11 m sprint, 11 m jogging, walking to start, 4 x
 - 2) 25 m sprint, 25 m jogging, walking to start, 2 x
 - 3) 50 m sprint, 50 m jogging, walking to start, 1 x

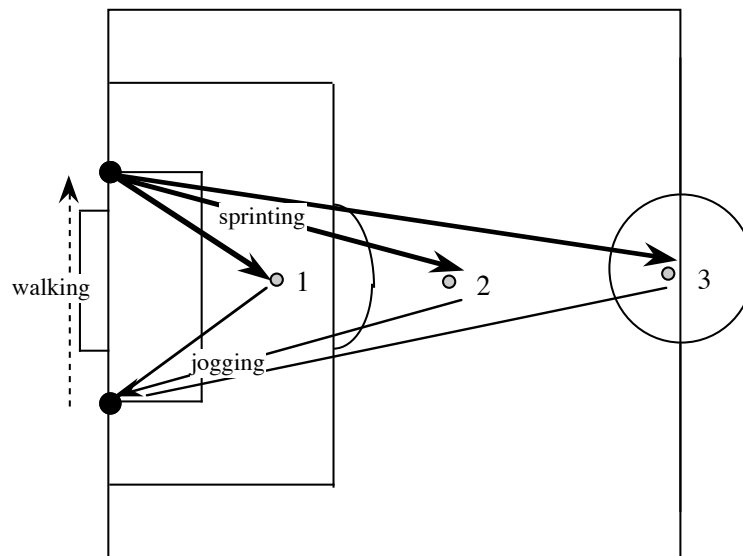

- Sprints should ideally start from a dynamic start position (walking, jogging, sideways or backwards...).
 - 5' recovery, followed by a 2nd Set of 7 sprints
 - The total exercise time is 15'
- * Cool down - 5' jogging and walking, followed by 10' extensive stretching

Total duration: 50'

Sun. 23rd: Those referees who don't have a game to officiate in the weekend, may do some intermittent activities such as playing badminton, football, squash, or tennis.